

# SUMMER OR WINTER...

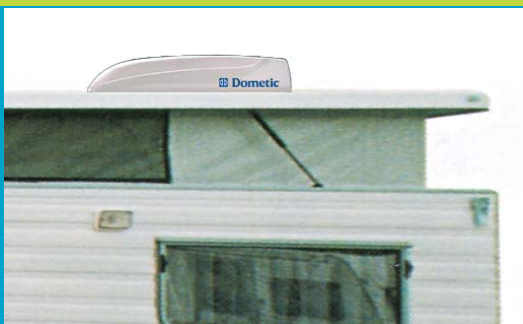









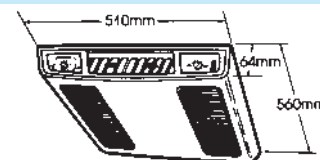
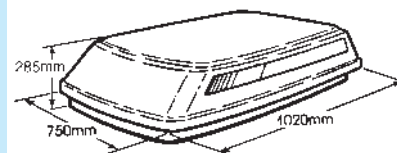

LET DOMETIC  
EXPAND  
YOUR  
RECREATIONAL  
VEHICLE  
SEASON

 **Dometic**

# Dometic Air Conditioner CAL136

● ● ● **THE LOWEST PROFILE IN THE INDUSTRY**











-  Ultra low aerodynamic profile.
-  Massive 13,500 BTU cooling capacity - compressor features a quick-start system while quietly delivering maximum cooling.
-  Ultra-quiet 3-speed fan enhances your comfort and provides controlled air circulation at the temperature you desire.
-  Compact interior panel allows more headroom.
-  No more hot spots - automotive style air louvres direct air flow right where you need it.
-  Removable and washable filters.
-  Heating - 5600 BTU output permits year-round comfort.
-  Features both a tough ABS plastic outer shroud and a bullet proof like galvabond inner shroud. The Dometic Air Conditioner is truly built to handle Australian conditions.
-  The CAL136 comes with a 1-year Dometic warranty.

DIMENSIONS	TECHNICAL DATA	
Roof opening: Length, mm . . . . . 360	Model designation . . . . . CAL 136	Air flow, Lit/Min. . . . . 7300
Width, mm . . . . . 360	Nominal Cooling capacity, kW approx. 3.0	Material, roof section Highly resistant ABS
Protruding	Voltage, Volts . . . . . 240	
Roof section: Length, mm . . . . . 1020	Amperage, Amp. . . . . 7.7	
Width, mm . . . . . 750	Circuit Protection . . . . . 10 AMP	
Height, mm . . . . . 285	. . . . . delayed	
Inside box: Length, mm . . . . . 560	Heating capacity, kW approx. . . . . 1.6	
Width, mm . . . . . 510	Amperage, Amp. . . . . 7.4	
Height, mm . . . . . 64		
Weight, kg approx. . . . . 50		

# Dometic Air Conditioner B1900S

● ● ● **1st POP TOP ROOF MOUNTED AIR CONDITIONER**



-  Light weight
-  Aerodynamic, modern design with ultra low profile
-  Easy and fast installation. Air distribution box already attached
-  Inside air vents sit flush with roof when unit is turned off
-  Two fan speeds for optimal air distribution
-  Suited for vans up to 16' 6" (external)
-  Removable washable air filter
-  B1900S comes with a 1-year Dometic warranty

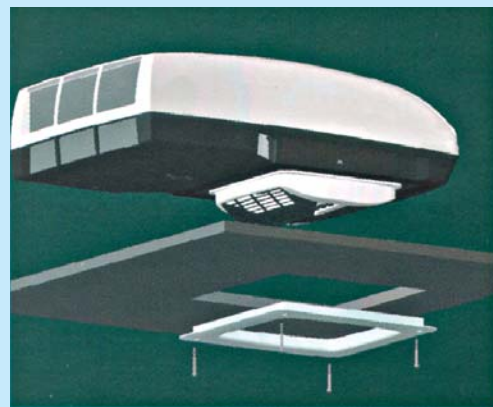

#### TECHNICAL DATA

Nominal Cooling Capacity, kW approx. . . . . 1.9  
 Voltage, Volts . . . . . 240  
 Heating capacity, kW approx. . . . . 1.2  
 Recommended Generator capacity kW . . . . . 2.5

#### DIMENSIONS

Roof opening: . . . . . Length, mm	400
. . . . . Width, mm	400
Roof section: . . . . . Length, mm	980
. . . . . Width, mm	650
. . . . . Height, mm	235
Weight, kg approx. . . . .	33

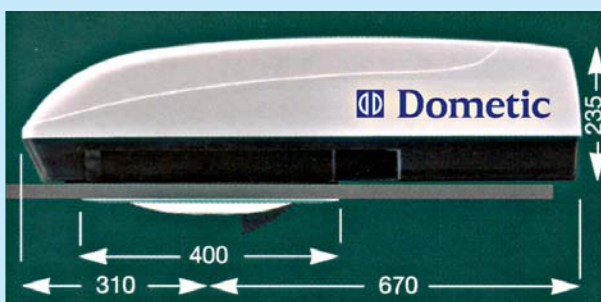
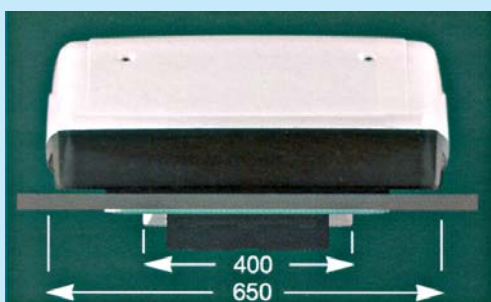

Modifications to your pop-top roof maybe required when installing this unit. Please check and confirm with your nearest dealer.

**Dometic**

# Air Conditioner B3300

## ● ● ● ROOF TOP AIR CONDITIONER

Keeping you comfortable with more cooling capacity than standard air conditioners

Dometic Engineers developed the B3300 cooling system with a highly efficient compressor, fan motor, blower wheel and specially designed custom coils to deliver maximum cooling comfort. An electric heating element provides warmth when desired. The unit installs in a standard 360mm vent opening, accommodates most roof thicknesses and is backed by a strong Dometic warranty.



The contoured Polar White shroud is High Molecular Weight Polyethylene (HMWPE)



Air Distribution Box (ADB)

### MODEL NO. B3300

#### DIMENSIONS

Roof opening:	Length, mm	360
	Width, mm	360
Roof Top	Length, mm	875
	Width, mm	510
	Height, mm	325
Protruding		
Inside box:	Length, mm	570
	Width, mm	510
	Height, mm	60
Weight, kg	approx.	44

#### TECHNICAL DATA

Nominal Cooling capacity, kW approx.	3.2
Voltage, Volts	240
Amperage, Amp.	5.6
Circuit Protection	10 AMP delayed
Heating capacity, kW approx.	1.6
Amperage, Amp.	7.4
Air flow, Lit/Min.	7,300

#### FAN

Speeds	3
--------	---

#### CONTROLS

Thermostat in ADB

#### MINIMUM GENERATOR SIZE





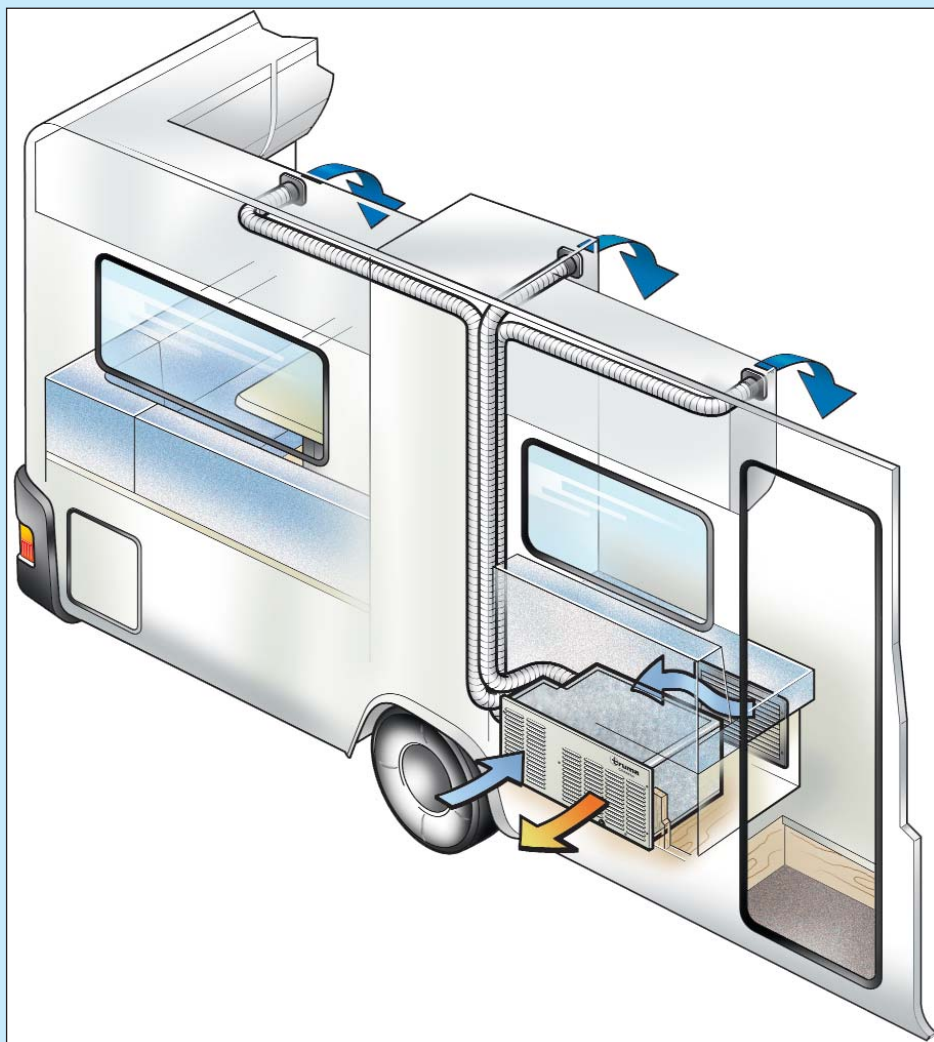

Unit kW	3.5
2 Unit kW	5.0

The interior Air Distribution Box (ADB) has safely recessed yet easy-to-reach manual controls. Fully adjustable louvers and three blower speeds provide just-right cooling comfort. Washable filter traps airborne particles to help keep the air and interior clean.

# Dometic Air Conditioner Climaster

## ● ● ● UNDERBUNK AIR CONDITIONER



-  Reverse cycle
-  One piece, precharged unit - no plumbing or connections required
-  Easy installation
-  Light weight
-  Suited for vans up to 16' 6" (external)
-  Dometic one year warranty

The Dometic Climaster under bunk airconditioner allows the freedom to direct airflow exactly to where it is needed. A three pipe connection on the unit allows for the nozzles to be installed precisely to suit individual needs.

#### TECHNICAL DATA

Nominal Cooling	
approx. capacity, kW	2.2
Voltage, Volts	240
Cycles, Hz.	50
Nominal Heating	
approx. capacity, kW	1.9
Recommended Generator	
capacity kW	2.5

#### DIMENSIONS

Unit size:	Length, mm	650
	Width, mm	420
	Height, mm	275
Weight, kg approx.		32

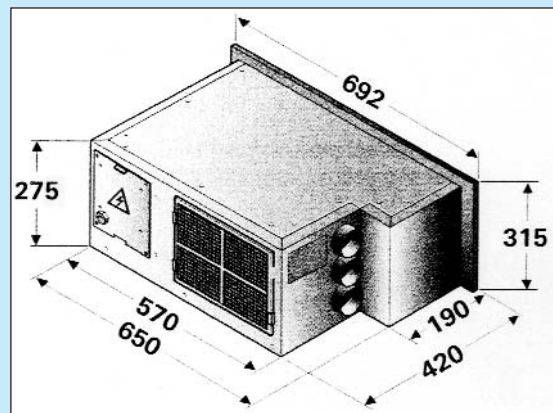



### Dometic Group Corporate Statement

Dometic is a customer driven, world-leading provider of innovative leisure products for the caravan, motorhome and marine markets. Dometic offers a complete range of air conditioners, refrigerators, awnings, cookers, sanitation systems, lighting, windows, doors and other equipment that makes leisure life more comfortable away from home.

Dometic also provides refrigerators for specific use in hotel rooms, offices and for storage of medical products and wine. Dometic's products are sold in almost 100 countries and are produced mainly in Dometic's own production facilities around the world. Annual sales amount to approximately 750 MEUR. Dometic has more than 4400 employees.



**Dometic Pty. Ltd.** A.B.N. 41 004 947 488

6 Treforest Drive, Clayton, Vic. 3168

Telephone: (03) 9545 5655

Facsimile: (03) 9545 5966

Email: [dometic@dometic.com.au](mailto:dometic@dometic.com.au)

Building 2, 129 Southpine Road, Brendale, Qld. 4500

Telephone: (07) 3205 7599

Facsimile: (07) 3881 1409

Dometic Pty. Ltd. may introduce modifications to their products from time to time and consequently the details given in this publication are subject to alteration without notice.

Distributed by: